

# RU SERIES WIRELESS REPEATER

RU series repeater is a part of our proprietary wireless sensor network based on Bluetooth technology. RU is designed to achieve ultra-low power consumption across the entire network, with individual node power consumption at the microwatt level, ensuring long-lasting sensor operation. It offers exceptional resistance to interference and boasts a high signal-to-noise ratio, ensuring stable and reliable communication. The remote wake-up feature allows users to query and control any node at their convenience, enabling flexible and intelligent monitoring and control. RU has been operating reliably and stably in various demanding industrial environments, providing a dependable foundation for the large-scale deployment of wireless sensors.

RU series wireless repeater is a repeater node in the wireless sensor networks. Its primary function is to receive data from sensor nodes and forward it to nearby gateways or other repeater nodes, enabling data transmission and extending the network's coverage range.

When used in conjunction with the GU series gateway, the RU series wireless repeater greatly expands the coverage range of the wireless sensor network. By strategically deploying the repeater nodes, it effectively addresses issues of long distances or weak signals between sensor nodes, ensuring reliable data transmission and stable network operation.

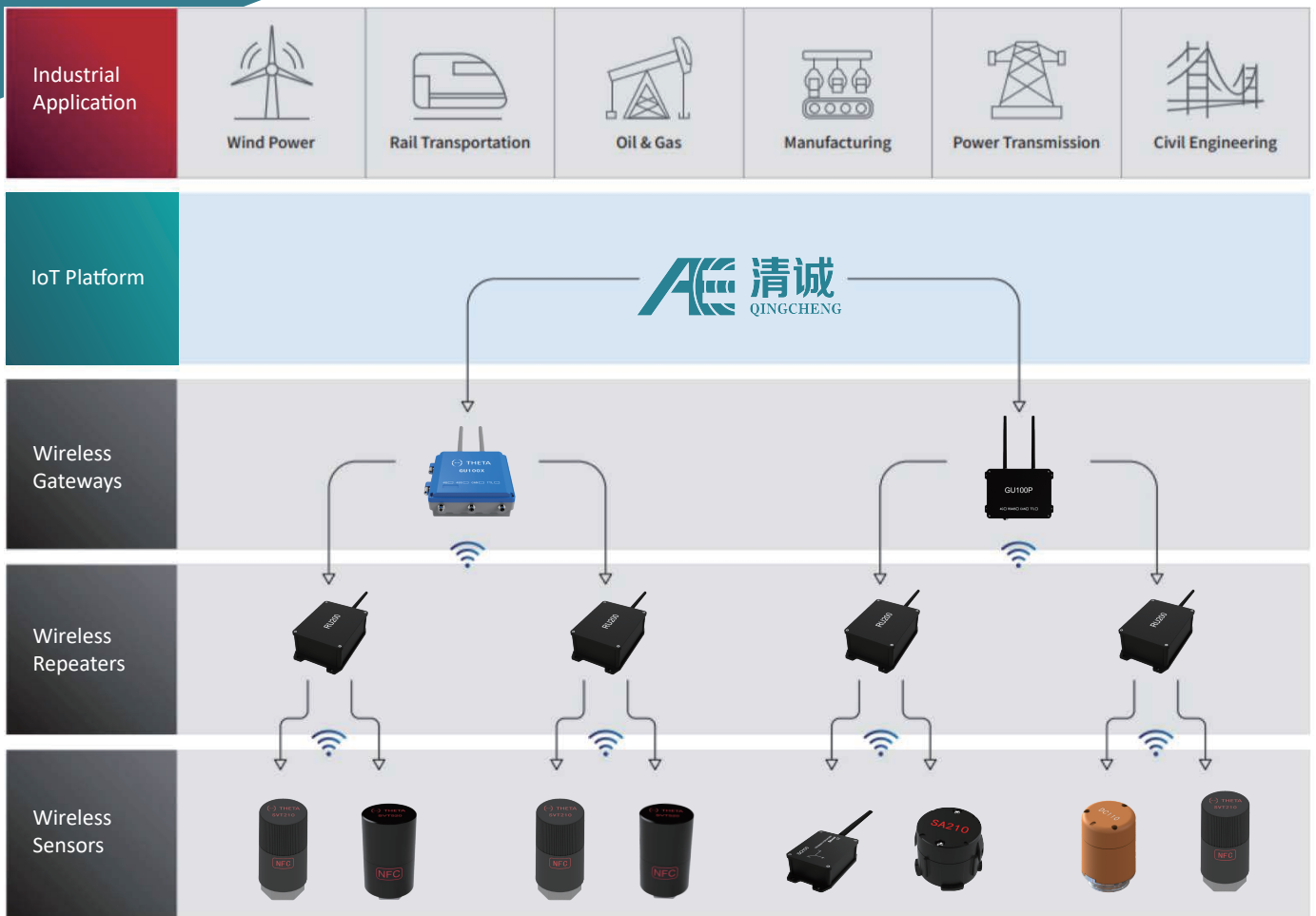

# RU SERIES

## WIRELESS REPEATER

### SPECIFICATIONS

Product Model	RU200
Wireless Sensor Network	2.4GHz Wireless Sensor Network (Bluetooth 5.0) Line-of-sight range:300 meters with sensor node and600 meters with gateway or another repeater node
Number of Nodes	64(including gateway and repeater)
Transmit Power	20dBm
Batteries	38000mAh Li/SOCL2 ER34615 x 2; replaceable
Dimensions	158mm x 104mm x 59mm (L x W x H)
Weight	1.0kg
Operating Temperature	-40~85°C
Operating Humidity	10%~90% RH
Enclosure	Metal
Ingress Protection	IP67
Mounting	Bolt fastening or strapping

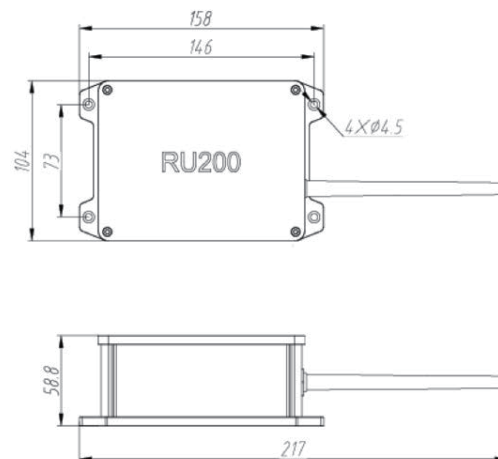

✉ sales2@ae-ndt.com

☎ +8619128609186

📍 Room 601-9, Building 3, 232 Kezhu Road, Huangpu District, Guangzhou, Guangdong, China

WWW.AENDT.COM